

ÉTABLI 6 TIROIRS AVEC PLAQUE INOX Réf.: 9611050601

Caractéristiques

Construction résistante à 1000 kg de charge statique. Plateau en bois multiplis de 40 mm. Bloc de rangement 6 tiroirs résistants à 25 kg, équipés de tapis de fond. Chaque tiroir peut contenir 3 modules simples (ajouter le jeu de calage adapté). Traverse métal (dim 1215x325 mm) pouvant servir d'étagère de rangement inférieure. Condamnation centralisée des tiroirs par clés. Serrure sur la face avant. Peinture époxy. Fixation possible au sol. Possibilité de fixer un étau sur le plateau. Livré avec une plaque inox : idéal pour les frappes fortes (peut être positionné soit à gauche soit à droite du plateau). Livré démonté : 5 éléments (1 plateau bois + 1 bloc servante + 1 pied + 1 traverse + 1 tôle inox)



Données produits

L mm	E mm	H mm	 kg	G	Ref.		Code EAN
2000	600	940	77,8	G10	9611050601	1	3303800013100

H mm Tiroir / Drawer 1	H mm Tiroir / Drawer 2	H mm Tiroir / Drawer 3	H mm Tiroir / Drawer 4	H mm Tiroir / Drawer 5	H mm Tiroir / Drawer 6	Lxl mm Tiroirs / Drawers
60	60	60	60	140	215	564x400



2, rue Bergognon
42500 LE CHAMBON-FEUGEROLLES - FRANCE
www.mob-mondelin.fr

NOTICE / INSTRUCTIONS

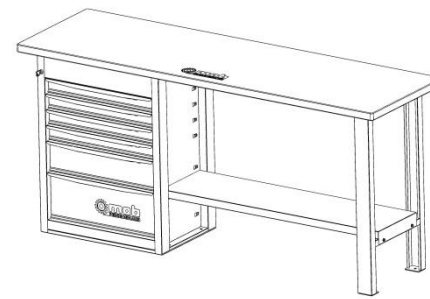
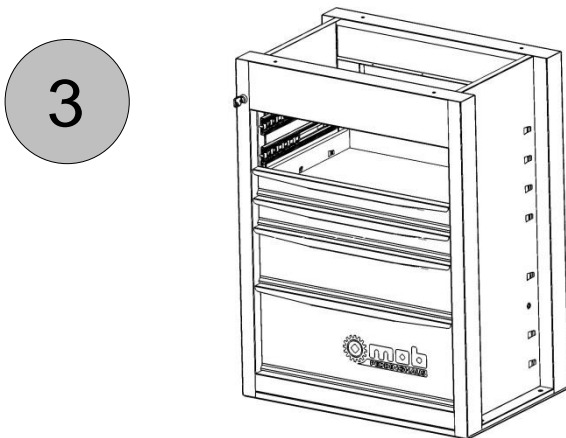
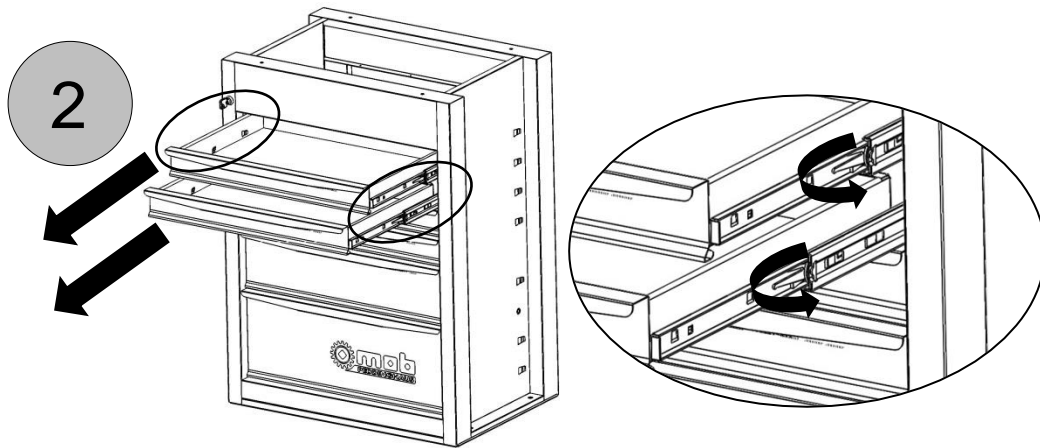
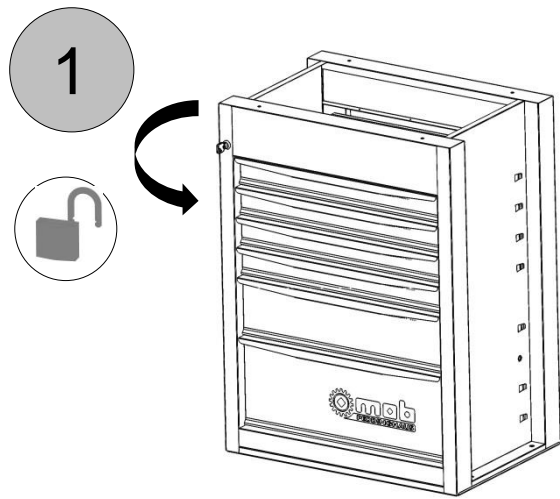

Ref.9611000601

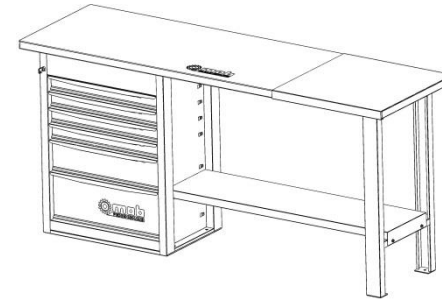

Ref.9611050601

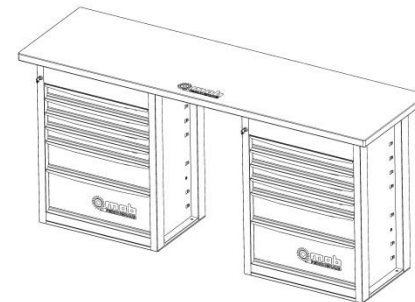

Ref.9611001201

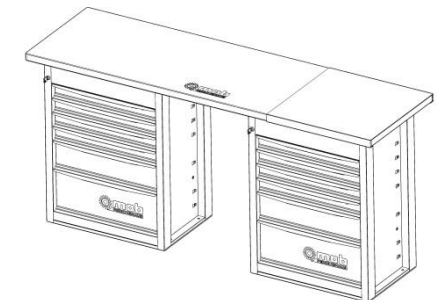

Ref.9611051201



